

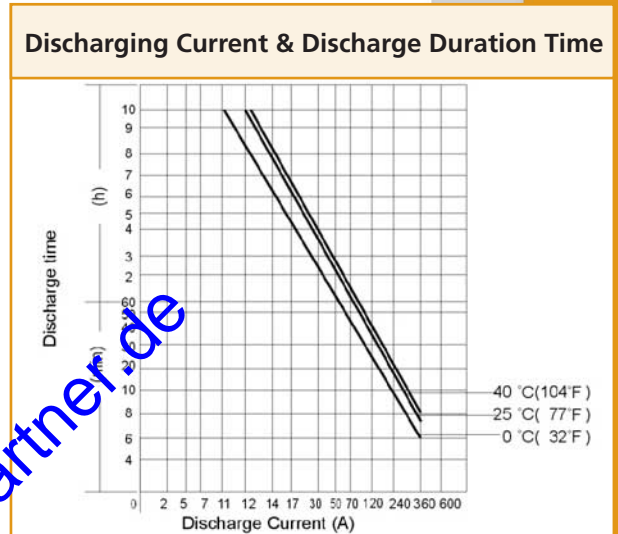

CTL 120-12

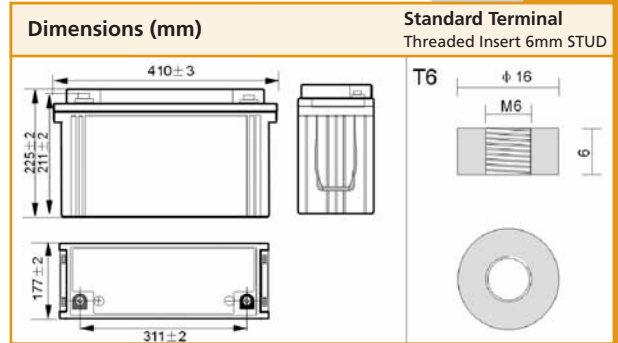

Physical Specification		
Nominal Voltage		12V
Nominal Capacity (10HR)		120AH
Dimension	Length	410±3mm (16.14 inches)
	Width	177±2mm (6.97 inches)
	Container Height	225±2mm (8.86 inches)
	Total Height (with Cover)	225±2mm (8.86 inches)
Weight		Approx 37.6kg (82.9 lbs)
Standard Terminal		Threaded Insert 6mm STUD

Electrical Specification					
Rated Capacity	20 hour rate (6.48A)	129 AH	Constant Voltage	Cycle	Initial Charging Current less than 36A, Voltage 14.4V~15.0V at 25°C (77°F) Temp. Coefficient -30mV/°C
	10 hour rate (12.4A)	124 AH			
	5 hour rate (21.3A)	106.5 AH			
	3 hour rate (32.0A)	96.0 AH			
	1 hour rate (74.4A)	74.4 AH			
Capacity affected by Temperature	40°C (104°F)	103%	Charge Standby		No limit on Initial Charging Current Voltage 13.5V~13.8V at 25°C(77°F) Temp. Coefficient -20mV/°C
	25°C (77°F)	100%			
	0°C (32°F)	86%			

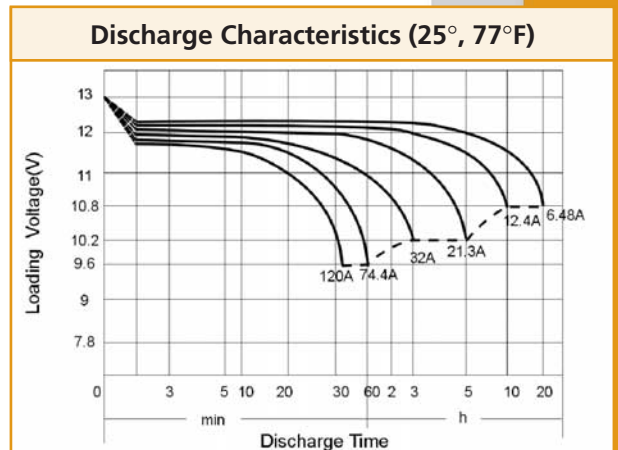

Constant Current (Amp) and Constant Power (Watt) Discharge Table (25°, 77°F)															
Amp/Watt/Cell	Time(minute)	10	15	20	30	45	60	120	180	240	300	360	480	600	1200
	Final voltage	1.3	1.3	1.3	1.6	1.6	1.67	1.7	1.75	1.75	1.75	1.75	1.8	1.8	1.8
A		310.0	235.6	186.0	142.6	99.2	74.4	43.4	32.0	24.8	21.3	18.8	14.8	12.4	6.48
W		582.8	446.4	364.6	269.1	197.2	147.3	86.3	64.0	49.5	42.5	37.7	29.5	24.5	12.98